



**GENTECH**  
POWER POWER WHEN YOU NEED IT

**POWER  
WHEN YOU  
NEED IT**

**2**  
YEAR  
WARRANTY

## Operators Manual

Please note: This manual is designed for the GP3500D, GP4000ES, GP8500D generators. The images used in the guide are for reference only and may differ slightly to the product itself.

## **CONTENTS:**

1. GENERAL SAFETY PRECAUTION & ENGINE OIL.....	1b
2. ELECTRICAL SAFETY PRECAUTIONS.....	2
3. SAFETY STICKERS AND EXPLANATIONS.....	3
4. SPECIFICATIONS.....	5
5. COMPONENTS.....	6
6. PRE OPERATION CHECKS.....	7-10
7. WHEELS AND HANDLES INSTALLATION.....	11
8. OPERATING PROCEEDURES.....	12-17
9. WATTAGE INFORMATION.....	17
10.MAINTENANCE SCHEDULE.....	18-19
11.HOW-TO MAINTENANCE .....	20-21
12.TRANSPORTING AND STORAGE.....	22
13.TROUBLE SHOOTING.....	23
14.WIRING DIAGRAM.....	24-25

## **IMPORTANT:**

Thank you for purchasing a Gentech Power & SHINERAY Gasoline Generating Set (hereinafter referred to as the "generator").

This manual will assist you in operating and maintaining your generator. This manual is the latest version. With the continuous improvement and upgrading of this product, the manufacturer reserves the right to modify this manual without notice. The manufacturer shall assume no liability for incorrect information contained in this manual.

This manual is an integral part of the generator. When the generator is transferred to others, this manual should be handed over to the new owner.

Some important information in this manual will be indicated in the following way ,please see below). The users should pay special attention to these instructions.

**The range of GENTECH POWER & SHINERAY GENERATORS is safe and reliable, but incorrect use of these products may cause personal injury and or damage to your machine. Please read this manual thoroughly before operation as this product is required to operate strictly in accordance with this manual.**

## **IMPORTANT NOTICES:**

### **PLEASE PAY SPECIAL ATTENTION TO STATEMENTS PRECEDED BY THE FOLLOWING WORDS:**



- **DANGER**

*This indicates a hazardous situation, which, if not avoided, will result in death or serious injury.*

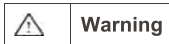

- **WARNING:**

*This indicates a hazardous situation, which, if not avoided, could result in death or serious injury.*

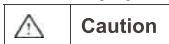

- **CAUTION:**

*This indicates a hazardous situation, which, if not avoided, could result in injury.*

## **Engine Oil:**

Gentech Power now supply the correct amount of oil to all generators.





**SAE 15W-40 Engine Oil**

**GP3500D Oil Capacity: 600ml**

**GP4000ES Oil Capacity: 600ml**

**GP8500D Oil Capacity: 1000ml**

# 1. GENERAL SAFETY PRECAUTIONS:

	<b>Danger</b>		<b>Warning</b>		<b>Caution</b>
---	---------------	---	----------------	---	----------------

- |   |  |
|---|--|
| <ul style="list-style-type: none"> <li>1.1. A "LAYMAN" and or "CHILDREN" may not recognize the possible dangers of operating a generator. We recommend that only competent persons should operate the generator.</li> <li>1.2. Fuel is combustible and easily ignited. Do not refuel during operation.</li> <li>1.3. Do not refuel whilst smoking or near naked flames. Do not overfill or spill fuel. If this happens clean the fuel on and around the generator properly before operating.</li> <li>1.4. Only use the specified fuel when operating the generator</li> <li>1.5. Some parts of the internal-combustion engine are hot and might cause burns. Pay attention to the warning signs on the generating set.</li> <li>1.6. Engine exhaust gases are toxic. Do not operate the generator in an unventilated room. When installed in a ventilated room, additional requirements for fire and explosion protection must be observed.</li> <li>1.7. Regularly check that the bolts and nuts are properly tightened as they may become loose due to vibration of the generator whilst in use.</li> <li>1.8. Before using the generator ensure that you have checked the periodic maintenance schedule in the operator's manual.</li> <li>1.9. Pay attention to the wiring or extension cords from the generator to the connected device. If the wire is under the generator or in contact with a vibrating part, it may break and possibly cause a fire, generator burnout, or electric shock hazard. Replace damaged or worn cords immediately.</li> <li>1.10. Do not operate in rain, wet or damp conditions, or with wet hands. The</li> </ul> | <ul style="list-style-type: none"> <li>operator may suffer severe electric shock if the generator is wet.</li> <li>1.11. If wet, wipe and dry it well before starting. Do not pour water directly over the generator, nor was hit with water.</li> <li>1.12. Be extremely careful that all necessary electrical grounding procedures are followed during each and every use. Failure to do so can be fatal.</li> <li>1.13. Do not connect the generator to a commercial power line. Connecting to a commercial power line may short circuit the generator. We strongly recommend the use of a Transfer Switch for connecting to a domestic circuit.</li> <li>1.14. Do not smoke when handling the battery. The battery emits flammable hydrogen gas, which can explode if exposed to cigarettes and or naked flames. Keep the area well-ventilated and keep naked flames/ sparks away when handling the battery.</li> <li>1.15. Keep children and all bystanders at a safe distance from the generator whilst in use.</li> <li>1.16. It is absolutely essential that you know and understand the safe and proper use of the power tool or appliance that you intend to connect to the generator. All operators must read, understand and follow the tool/ appliance operators manual. The tool and appliance applications and limitations must be understood. Keep all instruction manuals and in a safe place for future reference.</li> <li>1.17. Always switch off the circuit breaker on the generator when not in use.</li> <li>1.18. Do not store the generator inside a house or office. Do not store the generator where it will be exposed to rain or water.</li> </ul> |
|---|--|

## **2. ELECTRICAL SAFETY INFORMATION:**

- 2.1. Electrical equipment including cable, cords and plug connection must not be defective. Please check before using.
- 2.2. Do not plug the generator directly into a wall socket-outlet.
- 2.3. The generator should not be connected to other sources such as the power company supply mains. In special cases where stand-by connection to existing electrical systems or integration therewith is intended, note that it is a legal requirement that such connections or integration may only be performed by a competent person.
- 2.4. Protection against electrical shock depends on circuit-breakers that are specially matched to the generator. If a circuit breaker requires replacement, it shall be replaced by a circuit breaker that has identical ratings and performance characteristics.
- 2.5. Due to high mechanical stresses only tough rubber-sheathed flexible cable should be used.
- 2.6. If the generator is of CLASS II construction then earthing of the generator is not required.

### **2.7. Cord Extension Sets:**

- 2.7.1. A 1.0 mm<sup>2</sup> flexible cable can draw a maximum of 10 A provided that the cable is not longer than 25 m.
- 2.7.2. A 1.5 mm<sup>2</sup> flexible cable can draw a maximum of 10 A provided that the cable is not longer than 35 m
- 2.7.3. A 1.5 mm<sup>2</sup> flexible cable can draw a maximum of 16 A provided that the cable is not longer than 20 m
- 2.7.4. A 2.5 mm<sup>2</sup> flexible cable can draw a maximum of 10 A provided the cable is not longer than 65 m
- 2.7.5. A 2.5 mm<sup>2</sup> flexible cable can draw a maximum of 16 A provided that the cable is not longer than 45 m
- 2.7.6. A 4 mm<sup>2</sup> flexible cable can draw a maximum of 10 A provided that the cable is not longer than 100 m
- 2.7.7. A 4 mm<sup>2</sup> flexible cable can draw a maximum of 16 A provided that the cable is not longer than 65 m

### **2.8. DROP IN ELECTRIC EXTENSION CORDS:**

When a long electric extension cord is used to connect an appliance or tool to the generator, a certain amount of voltage drop or loss occurs in the extension cord which reduces the effective voltage available for the appliance or tool.

The chart below has been prepared to illustrate the approximate voltage loss when an extension cord of 300 feet (approx. 100 meters) is used to connect an appliance or tool to the generator.

Nominal cross section	A.W.G.	Allowable current	No. of strands/ strands dia.	Resistance	Current Amp.							Voltage drop
					1A	3A	5A	8A	10A	12A	15A	
mm2	No.	A	No./mm	/100m	1A	3A	5A	8A	10A	12A	15A	
0.75	18	7	30/0.18	2.477	2.5V	8V	12.5V					
1.27	16	12	50/0.16	1.486	1.5V	5V	7.5V	12V	15V	18V		
2	14	17	37/0.26	0.952	1V	3V	5V	8V	10V	12V	15V	
3.5	12 to 10	23	45/0.32	0.517		1.5V	2.5V	4V	5V	6.5V	7.5V	
5.5	10 to 8	35	70/0.32	0.332		1V	2V	2.5v	3.5V	4V	5V	

### 3. SAFETY STICKERS AND EXPLANATIONS:





#### 4. SPECIFICATIONS:

<u>ITEM</u>		GP2500R	GP2500D	GP3500D	GP4000ES	GP6500D	GP7500D	GP8500D	
<b>ENGINE</b>		SR170F	SR170FE	SR170FE	SR170FE	SR188FE	SR190FE	SR192FE	
	ENGINE TYPE	OHV, 25 tilt, Single Cylinder, Forced Air Cooling, 4-Stroke							
	BORE STROKE (MM)	70X55	70X55	70X55	70X58	88X64	90X66	92X67	
	DISPLACEMENT (ML)	212	212	212	223	389	420	445	
	LUBRICATING TYPE	SAE 15W-40							
	IGNITION SYSTEM	T.C.L.							
<b>GENERATOR SPECIFICATION</b>	STARTING SYSTEM	Recoil Start	Electric Start						
	RATED VOLTAGE (V)	230V							
	RATED FREQUENCY (Hz)	50							
	RATED OUTPUT (KW)	2	2	2.5	3.2	5	6	7	
	RATED CURRENT (A)	8.7	8.7	10.7	13.9	21.7	26	30.4	
	MAXIMUM OUTPUT (KW)	2.2	2.2	2.8	3.5	5.5	6.5	7.5	
	POWER FACTOR (COS)	1							
	PHASE	Single							
	FUEL TANK CAPACITY(L)	15	15	15	15	25	25	25	
	OIL CAPACITY(L)	0.6	0.6	0.6	0.6	1.1			
	FUEL LOAD CONSUMPTION(L/H)	1.7	1.7	1.7	1.7	3.1	3.5	3.5	
	FUEL LOAD CONTINUOUS RUN TIME(H)	9	9	9	9	8	7	7	
	NOISE LEVEL {Db(A)}	≤94	≤94	≤94	≤94	≤96	≤96	≤96	
	REGULATING SYSTEM	Advanced Automatic Voltage Regulator(AVR)							
	PACKAGE DIMENSIONS (L*W*H)(mm)	610X460X465				700X600X580			
	CONTAINER LOADING QTY (20/40/40H)	225/475/475	225/475/475	225/475/475	225/475/475	108/228/228		108/228/228	
N.W(Kg)	42	44	44	49	95	98	100		
G.W(Kg)	44	46	47	53	99	102	104		

**Specifications are subject to change without notice.**

#### **ELECTRIC START MODEL:**



## 5. COMPONENTS:

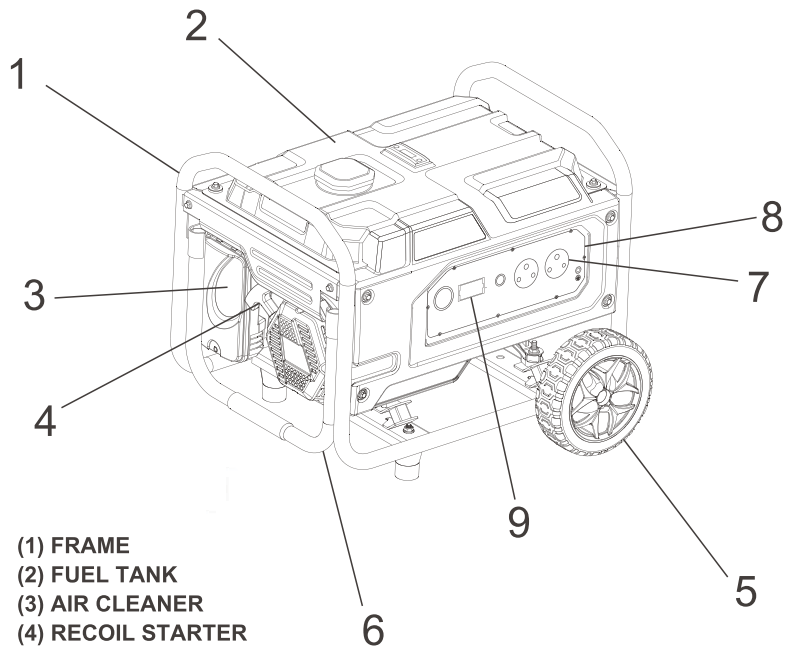

- (1) FRAME
- (2) FUEL TANK
- (3) AIR CLEANER
- (4) RECOIL STARTER
- (5) TOLLEY WHEEL
- (6) HANDLE
- (7) SOCKET
- (8) CONTROL PANEL
- (9) DIGITAL METER

## 6. PRE-OPERATION CHECKS:

### 6.1. CHECKING THE ENGINE OIL:

- 6.1.1. Ensure that the generator is on a flat and level surface before adding oil.
- 6.1.2. Remove the oil cap and check the level of the oil
- 6.1.3. Add oil to the generator if the oil is below the indicator line
- 6.1.4. Always ensure that your engine oil is clean.

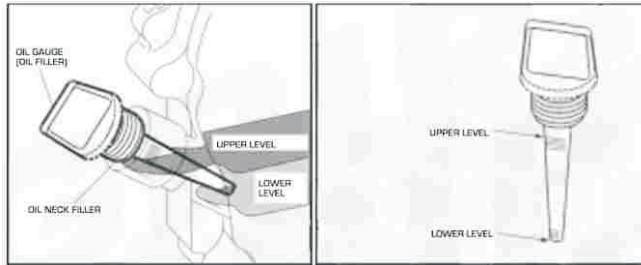

### 6.2. OIL CAPACITY FOR THE VARIOUS GENERATOR MODELS:

- |       |                  |       |                  |
|-------|------------------|-------|------------------|
| 6.2.1 | GP3500D - 600ml  | 6.2.2 | GP4000ES - 600ml |
| 6.2.3 | GP8500D - 1000ml |       |                  |

### 6.3. RECOMMENDED ENGINE OIL:

- 6.3.1. Only use 4-stroke automotive oil (API or SE) alternatively you can use a higher grade (SG, SH or SJ). **SAE 15W-40** is recommended for general all-temperature use. If single viscosity oil is used, select the appropriate viscosity for the average temperature in your area.

Single grade	5W						
	10W						
Multigrade							
Ambient temperature	-20	-10	0	10	20	30	40°C
	-4	14	32	50	68	86	104°F

### 6.4. CHECKING THE ENGINE FUEL:



**Warning**

**Do not refuel while smoking or near an open flame or other potential fire hazards.**

- 6.4.1. Use the fuel gauge to check the fuel level.
- 6.4.2. If the fuel level is too low, only refuel with unleaded fuel

6.4.3. Ensure that you use the fuel filter screen on the fuel filter

## **6.5. FUEL CAPACITY FOR THE VARIOUS GENERATOR MODELS:**

6.5.1 GP3500D - 15L

6.5.2 GP4000ES - 15L

6.5.3 GP8500D - 25L

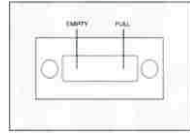
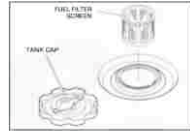

Make sure you review each warning in order to prevent fire hazards. Do not refill the fuel tank whilst the engine is running or hot. Please ensure that the fuel cock is closed before refueling. Be careful not to contaminate the fuel with any dust, dirt, water or other foreign liquids/objects. Please lean all spilled fuel thoroughly before starting the generator.

**Ensure that the generator is clear from any open flames. Do not smoke whilst refueling the generator.**

### **6.6.CHECKING COMPONENT PARTS:**

Before starting the generator please check the following:

6.6.1. Check for any fuel leaking from any part of the generator.

6.6.2. Check that all the nuts and bolts are securely tightened on the generator.

6.6.3. Check for any visible damaged components on the generator.

6.6.4. Check that the generator is not resting on or adjacent to any electrical wiring.

### **6.7. CHECK THE GENERATOR SURROUNDINGS:**

#### **WARNING:**

Make sure you review each warning in order to prevent fire hazards. Keep the surrounding area clear of flammables or other hazardous materials. Keep the generator at least 3 feet (1 meter) away from all buildings and or other structures. Only operate the generator in a dry, well-ventilated area. Keep the exhaust pipe clear of all foreign objects. Keep the generator away from open flames. Do not smoke in close proximity to the generator. Keep the generator on a flat and level surface.

Do not attempt to block the generator air vents with any paper or other material/objects.

### **6.8. LITHIUM BATTERY OPERATION**

**The recommended battery capacity is 0.8A and 1.6A.**

#### **Health Warning**

The electrolyte inside the battery is harmful to skin and eyes. If the battery leaks and the electrolyte gets into your eyes, do not rub them. Instead, rinse them with clean running water and immediately seek medical attention. If left untreated, electrolyte can cause permanent injury to your eyes.

#### **Installation**

- Check the battery voltage with a voltmeter before fitting. If the voltage is less than 12.8 volts, do a refresh charge (see charging section).

- Always follow the manufacturer's instruction guidelines when connecting the battery.
- Connect the positive and negative leads correctly.
- Fit the battery with spacer when needed for best possible fit.

### **Charging**

- Both the generator and battery charger need to limit the voltage between 14.0-15.0 volts when charging. The battery cannot be fully charged if charging voltage is less than 14.0 volts, and the battery would be damaged if the charging voltage is over 15.0 Volts.
- The battery must be charged using the standard current specified in charging label if the voltage is less than 8V.
- Always remove the battery from the generator before charging separately.
- Charge the battery with a lower current rather than the MAX Charging Current found on the Charging label.
- After charging, leave the battery for 1 to 2 hours before checking the voltage. If the voltage is less than 12.8 volts, additional charging is required.
- If the battery becomes too hot to touch, stop charging. Allow battery to cool before resuming.

### **Storage**

- The battery should be stored with approximately 70% charge state.
- The battery should be stored in clean, dry and ventilated environment (-20-40 Degrees Celsius), not in contact with any corrosive substance and away from heat and fire.
- The battery should be charged completely once every 180 days when in storage.

### **Transportation**

- The battery should be transported with approximately 70% charge state.
- The battery should be packed with insulation and shockproof material to avoid damage from sudden jolts and collision.
- The battery should be handled with care when loading and unloading during transport. Do not throw the batteries and avoid collision.
- Do not transport the batteries together with flammable, explosive objects, or sharp metal goods.

### **Maintenance**

- Disconnection of the battery cable is always the best choice if the generator is in storage or used infrequently. Use a standard charger to maintain the battery.
- If the battery stands by for any period of time, check the voltage in case the voltage is lower than 12.8 Volts, and recharge according to the charging label.

Keep the connecting poles clean and securely fastened.

The battery is factory sealed and requires no topping up of any fluid. Never attempt to open the battery.

- Do not immerse the battery in water.
- Do not use or store the battery near sources of fire or heat.
- Do not reverse the positive (+) or negative (-) terminals.
- Do not connect the battery directly to wall outlets.
- Do not put the battery into a fire or apply direct heat to it.

- Do not short-circuit the battery by connecting wires or other metal objects to the positive (+) and negative (-) terminals.
- Do not pierce the battery casing with a nail or other sharp objects, break it open with a hammer, or step on it.
- Do not strike, throw, or subject the battery to sever physical shock.
- Do not directly solder the battery terminals.
- Do not attempt to disassemble or modify the battery in any way.
- Do not place the battery in a microwave oven or pressurized container.
- Do not use the battery in combination with primary batteries (such as dry cell batteries) or batteries of different capacity, type, or brand.
- Do not use the battery if it gives off an odor, generates heat, becomes discolored or deformed, or appears abnormal in any way. If the battery is in use or being recharge, remove it from the device or charger immediately and discontinue use.
- Do not use more than one battery in parallel or in series.
- Do not press on indicator button longer than few seconds.
- Do not dispose the battery before completely discharge.
- Do not charge the battery by charging voltage over 15.0V.
- Do not charge the battery by charging with an automatic "desulfation mode" function.
- The battery will fail if over charged, it may happen to deform or fume.
- Please fix the battery terminal with original screws and nuts securely.
- The cranking performance will be affected when environment temperature lower than -5°C. Keep out of reach of Children and Pets.

## 6.9. **GROUNDING THE GENERATOR:**

- 6.9.1. When grounding the generator connect the grounding lug of the generator to the grounding spike.
- 6.9.2. If such grounding conductor or ground electrode is unavailable, connect the grounding lug of the generator to the grounding terminal of the electric tool or appliance.

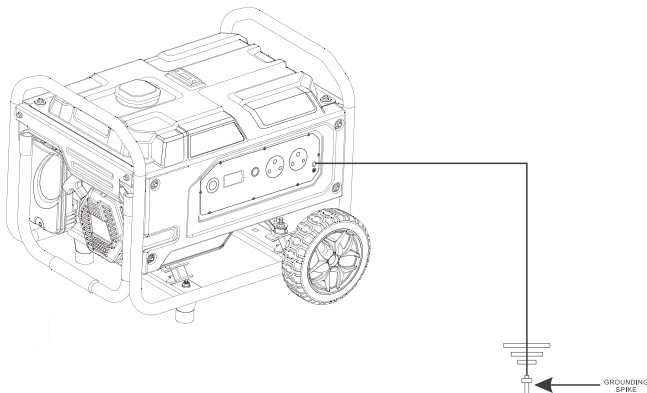

## 7. WHEELS AND HANDLES INSTALLATION:

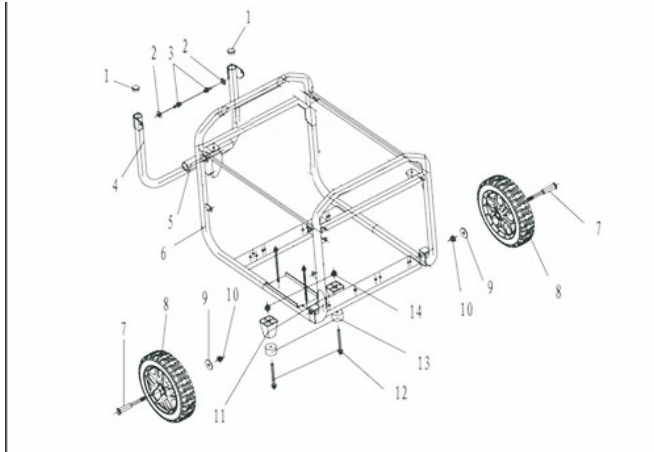

- |                          |                       |                    |
|--------------------------|-----------------------|--------------------|
| 1. PROTECT BLOCK/STOPPER | 2. LINING, HANDLE     | 3. BOLT M8*16      |
| 4. HANDLE                | 5. GRIP, HANDLE       | 6. FRAME           |
| 7. AXLE, WHEEL           | 8. WHEELS             | 9. WASHER FLAT-Φ10 |
| 10. NUT NYLOC M10        | 11. SUPPORTER, RUBBER |                    |
| 12. BOLT M8*90           | 13. FOOT, RUBBER      | 14. NUT M8         |

### 7.1. INSTALLATION STEPS:

1. Insert 7 into 8 and put 9 on 7, then install 7 into the mounting holes of 6 and fix by 10.
2. Fix 4 to 6 by 3 and 2.
3. Mount 5 and 1 on 4.
4. Install 13 and 11 by 12, then fix them on 6 by 14.

## 8. OPERATING PROCEDURES:

### 8.1. STARTING THE GENERATOR ENGINE:



**Warning**

Every time before starting the generator please ensure that you check the oil level

- 8.1.1. Turn the choke lever to the “start” position if the engine is cold.
- 8.1.2. Turn the circuit breaker to the “OFF” position.
- 8.1.3. Open the fuel cock.
- 8.1.4. Turn on the battery switch and press the push start button.
- 8.1.5. For manual start machines pull the recoil starter until resistance is felt.
- 8.1.6. This is the “compression” point. Return the handle to its original position, and then pull swiftly.
- 8.1.7. If the generator engine fails to start after several attempts, repeat above the procedures with the choke knob returned to the “RUN” position.
- 8.1.8. Do not pull the rope of the recoil starter out completely.
- 8.1.9. After starting the generator allow the starter handle to return to its original position whilst still holding on to the handle.

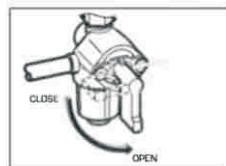
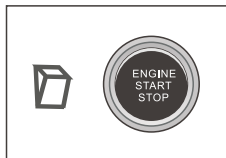

**For the GP2500R, GP2500D, GP3500D, GP4000ES, GP6500D, GP7500D, GP8500D generator models please refer to Figure 2.**

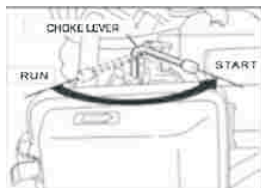

Figure 1

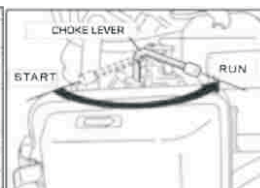
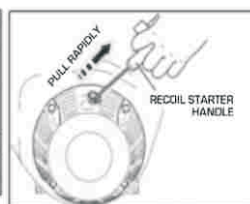

Figure 2



**NOTE:** If you are starting the generator for the first time we recommend that you use the recoil starter.



### Caution

Do not attempt to run the starter motor for more than 5 seconds continuously. If the generator engine fails to start, return the key to the "RUN" position and wait about 10 seconds before attempting to start it again. Do not turn the key switch to the "START" position when the generator engine is running as this could damage the starter motor. When attempting to start the generator engine using the recoil starter ensure that the key is in the "ON" position before pulling the recoil starter handle.

8.1.10 After the engine has started, please return the choke lever to the " RUN " position.

**For the GP2500R, GP2500D, GP3500D, GP4000ES, GP6500D, GP7500D, GP8500D generator models please refer to Figure 2.**

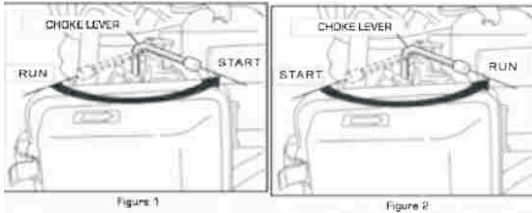

8.1.11 Always let the generator engine warm up sufficiently

## 8.2. USING ELECTRIC POWER:



### Warning

Do not move the generator while it is running.  
Be sure to ground the generator if the connected appliance is grounded. Failure to ground the unit may lead to electrical shock.

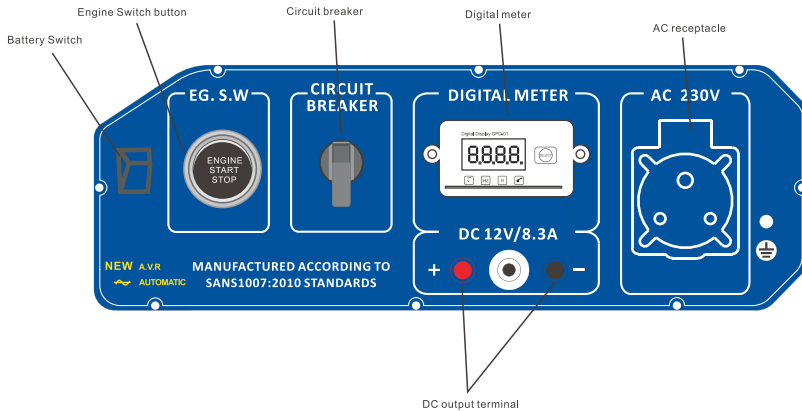



8.2.1. **AC APPLICATION:**

- 8.2.2 Check the digital meter for sufficient voltage.
- 8.2.3. This generator is properly tested and adjusted and set at the factory.
- 8.2.4. If the generator does not produce the specified voltage please contact **GENTECH INDUSTRIES, the OFFICIAL SERVICE AGENTS COUNTRYWIDE for all models of GENTECH GENERATORS.**
- 8.2.5. Turn off the switch (es) of the electrical appliance(s) before connecting to the generator.
- 8.2.6. Insert the plug(s) of the electrical appliance(s) into the receptacle.
- 8.2.7. Check the amperage of the receptacles used making reference to the TABLE on page 4 and be careful not to take a current exceeding the specified amperage.
- 8.2.8. Check that the total wattage of all appliances that is being connected to the generator does not exceed the rated output of the generator.
- 8.2.9 Turn on the appliance switch.

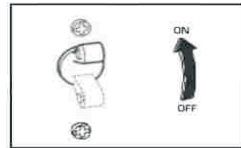
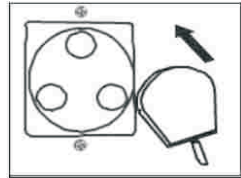
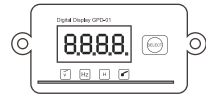

**NOTE:** If the circuit breaker “TRIPS” during operation the generator is overloaded or the appliance is defective. Stop the generator immediately and check the appliance and /or generator for overloading.

**8.3 CONNECTING TO DOMESTIC CIRCUITS (HOUSE WIRING):**

 **Warning**

If a generator is to be connected to residential or commercial power lines for stand-by power during power outage- all connections must be made by a competent person/ licensed electrician. Connection failure, or improper connection, may result in death, personal injury, damage to the generator, damage to the appliances, damage to the building's wiring, or even result in a fire.

- 8.3.1. When connecting the generator to the house wiring the generator output power must be taken from the 230V receptacle.
- 8.3.2. A transfer switch must be installed to transfer the load from the commercial power source to the generator. This switch is necessary to prevent accidents caused by the recovery from power outages. Use a transfer switch of the correct capacity. Install the transfer switch between the meter and the fuse or AC Breaker Box.

 **Caution**

If the neutral wire of the house wiring is earthed, be sure to earth the ground terminal of the generator. An electric shock may result if this procedure is not followed.

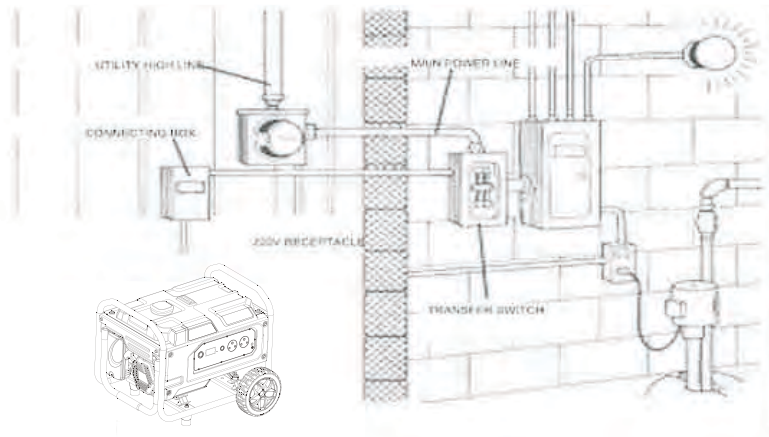

## 8.4 STOPPING THE GENERATOR:

- 8.4.1 Turn off the power switch of the electric equipment and unplug the cord from the receptacle of the generator.
- 8.4.2 Turn the circuit breaker to the "OFF" position.
- 8.4.3 Allow the engine to cool down for about three minutes with no load prior to switching it off.
- 8.4.4 For recoil starter models turn the switch to the "OFF" position
- 8.4.5 For electric start models, press the button to stop the engine and turn off the battery switch.
- 8.4.6 Close the fuel cock.

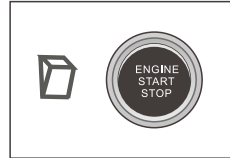

## 8.5 OIL SENSOR:

- 8.5.1 The oil sensor detects a drop in the oil level in the crank case and automatically stops the engine when oil level drops below a predetermined level.
- 8.5.2 When engine has stops automatically switch off the generator's circuit breaker and check the oil level. Refill with engine oil to the upper level as instructed on clause 6.1, and then restart the engine.
- 8.5.3 If the engine does not start please recheck the oil level.

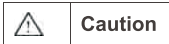
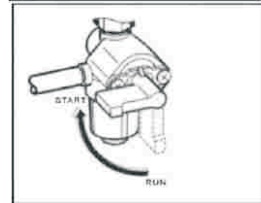
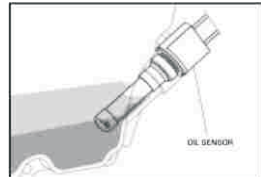

**Caution**

Do not remove the OIL SENSOR PROBE when refilling with oil. Remove the oil filler cap on the opposite side of carburetor.

## 8.6 FOUR STAGE DIGITAL METER:

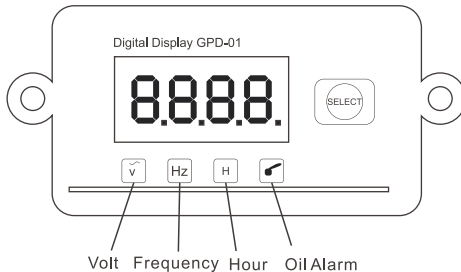

- 8.6.1 **Voltage Display Range:** 160 V – 250 V (a.c single phase)

- 8.6.2 **Digital Meter Display:** The display shown on the digital meter 6 minutes prior to switching off the machine will be the first display shown when restarting the machine.

- 8.6.3 **LCD Display:** Press the “SELECT” button to change the LCD display from voltage, hours run, frequency and oil level.
- 8.6.4 **Hour Run/ Time Indicated on the Digital Meter:** 0.1h = 6 minutes, 0.2h = 12 minutes. The meter display will only change every 6 running minutes.
- 8.6.5 **Display Frequency:** ≥30 Hz (EG: 50 Hz will display as F-50)
- 8.6.6 **Display Voltage:** 160 ~ 250 V a.c (EG: 230 V will display as U230)
- 8.6.7 **Oil Level Display:** If there is insufficient oil in the machine the oil light will flash red and the machine will automatically switch off. Do not attempt to restart the machine until you have re filled with oil.
- 8.7.8 **Digital Meter Maintenance Display Tips:**
1. **P-25:** Machine requires the oil to be changed.
  2. **P-50:** Machine requires the air filter element and the oil to be changed.
  3. **P-100:** The machine requires the fuel filter, air filter element and the oil to be changed.

**NOTE:** THE MAINTENANCE TIPS AS INDICATED ABOVE, ONCE DISPLAYED, WILL NOT SHOW AGAIN AFTER THE MACHINE HAS BEEN SWITCHED OFF AND THEN RESTARTED.



**CAUTION:** DO NOT TAMPER OR OPEN THE DIGITAL METER AS IT WILL NULLIFY YOUR WARRANTY AND MAY ALSO LEAD TO AN ELECTRIC SHOCK.

## **9. WATTAGE INFORMATION:**

- 9.1 Some appliances need a “**surge**” of energy when starting. This is commonly known as a “**LAGGING**” Load.
- 9.2 This means that the amount of electrical power needed to start the appliance may exceed the amount needed to maintain its use.
- 9.3 Electrical appliances and tools normally come with a label indicating voltage, cycles/Hz, amperage (amps) and electrical power needed to run the appliance or tool.
- 9.4 Check with your nearest branch with questions regarding power surges of certain appliances or power tools.
- 9.5 Electrical loads such as incandescent lamps and hot plates require the same wattage to start as is needed to maintain their use. This is commonly known as a “**LEADING**” Load
- 9.6 Loads such as fluorescent lamps require 1.5 to 2 times the indicated wattage during start-up.
- 9.7 Electrical motors require a large starting current. Power requirements depend on the type of motor and its use. Once enough “**power**” is attained to start the motor, the appliance will require only +-50% of the wattage in order to continue running.
- 9.8 Most electrical tools require 1.5 to 3 times their wattage for running under load during use. Loads such as submersible pumps and air compressors require a very large force to start. They need 3 to 5 times the normal running wattage in order to start.

**NOTE: PLEASE REFER TO THE CONSUMPTION CHART AND LOAD CALCULATOR IN THE QUICK REFERENCE GUIDE BOOKLET.**

## 10. MAINTENANCE SCHEDULE:

FOR ALL YOUR SERVICE, MAINTENANCE AND WARRANTY QUERIES PLEASE CONTACT GENTECH INDUSTRIES. PLEASE REFER TO THE BACK PAGE FOR ALL CONTACT DETAILS.

### 10.1 DAILY INSPECTION:

Before starting the generator please check the following service items: These basic inspections can be carried out by a “Laymen”.

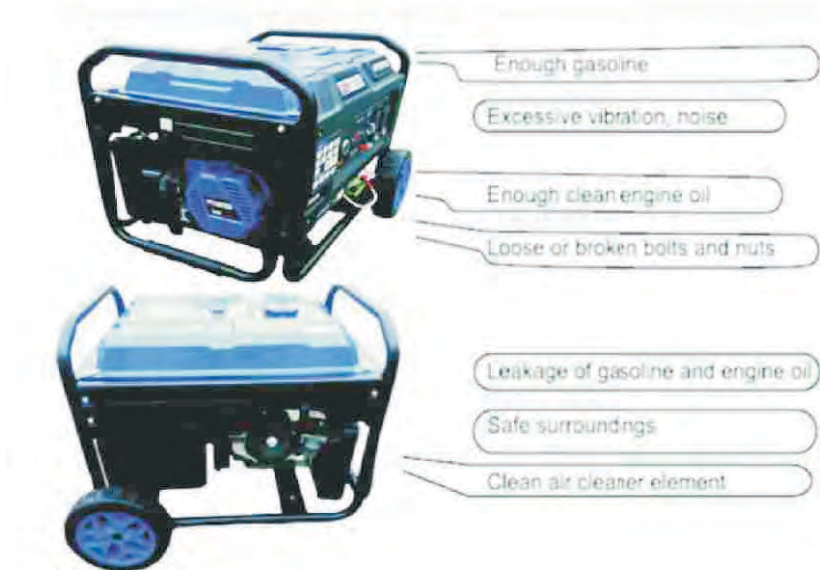

### 10.2 PERIODIC MAINTENANCE:

Periodic maintenance is vital for the safe and efficient operation of the generator. Check the table below for periodic maintenance intervals.

**IT IS ALSO NECESSARY TO CONDUCT THE MAINTENANCE AND ADJUSTMENTS ON THE EMISSION RELATED PARTS LISTED BELOW TO KEEP THE EMISSION CONTROL SYSTEM EFFECTIVE. WE RECOMMEND THAT THIS MAINTAINANCE IS CARRIED OUT BY A QUALIFIED TECHNICIAN.**

**The emission control system consists of the following parts:**

- (1) Carburetor and internal parts
- (2) Cold start enrichment system, (if applicable)
- (3) Intake manifold, (if applicable)
- (4) Air cleaner elements
- (5) Spark plug
- (6) Magneto or electronic ignition system
- (7) Spark advance/retard system, (if applicable)
- (8) Exhaust manifold, (if applicable)

(9) Hoses, belts, connectors and assemblies

The maintenance schedule indicated in the table is based on normal generator operation. Should the generator be operated in extremely dusty conditions or in heavier loading conditions, the maintenance intervals must be shortened. This will depend on the contamination of oil, logging of filter elements and the wear and tear of parts.

**10.2.1 PERIODIC MAINTENANCE TABLE:**

**Below is the periodic maintenance table for the Gentech & SHINERAY Range of Generators. You are required to service and maintain the generator in accordance with this schedule. Failing to do will nullify your warranty policy. You may be required to provide the service history of the generator should it be requested.**

MAINTENANCE PARTS	DAILY	EVERY 20 HOURS	EVERY 50 HOURS	EVERY 100 HOURS	EVERY 200 HOURS
Clean Generator and check all nuts and bolts	*				
Tighten Wheels and Axle			*		
Check and refill engine oil		*			
Replace Engine Oil		initial	*		
Clean and Adjust Spark Plug and Electrodes			*		
Replace Spark Plug				*	
Clean Air Filter			*		
Replace Air Filter Element				*	
Clean Fuel Strainer			*		
Replace Fuel Strainer				*	
Remove Carbon from Cylinder Head					*
Clean and Adjust Valve Clearance				*	
Clean and Adjust Carburetor					*
Replace Carbon Brushes				*	
Replace Fuel Lines				*	
Charge Battery		initial	when generator not in use		

**\*NOTE:** The initial oil change should be performed after the first twenty (20) hours of operation thereafter only change the oil every one hundred (50) hours.

**\* NOTE:** We recommend that all maintenance is carried out by a qualified technician. Proof of such maintenance will be required for warranty purposes.

10.2.2 Before changing the oil, please try to look for a suitable way to dispose of old oil.

10.2.3 Do not pour it down drains, onto garden soil or into open streams. Your local zoning or environment instructions on proper disposal.

## 11. “HOW – TO” MAINTENANCE:

### 11.1. ENGINE OIL CHANGE:

We recommend that you change the engine oil every 50 hours. (For a new engine please change the engine oil after the first 20 hours.)

11.1.1 Drain the oil by removing the drain plug and the oil filler cap while the engine is still warm.

11.1.2 Once the oil has completely drained out reinstall the drain plug and fill the engine with oil until it reaches the upper level on the oil filler cap. **DO NOT OVER FILL.**

11.1.3 Only use clean high quality lubricating oil. Do not use old or dirty oil as this will affect the performance and longevity of the generator. This generator is fitted with an **OIL ALERT SENSOR** and will **NOT** start if there is insufficient oil in the sump/engine.

**\*NOTE:** This generator is fitted with an **OIL ALERT SENSOR** and will **NOT** start if there is insufficient oil in the sump/engine.

### 11.2 CLEANING AIR FILTER:



Do not wash the elements with kerosene, gasoline or oil.

A dirty air filter element will make the starting of the generator difficult. It will also cause the generator to under-perform and may cause permanent damage. **Always keep the air filter element clean.**

11.2.1 The urethane foam element must be washed with a cleaning detergent. After cleaning it ensure that it is dried properly before reinstalling. **Please clean every 50 hours.**

11.2.2 Clean the paper element by tapping and blowing it gently to remove dirt and dust. Never use oil to clean the paper element. **Please clean every 50 hours and replace every 100 hours.**

**\*NOTE:** Please clean the air filter elements more often when operating in dusty environments.

### 11.3 CLEANING AND ADJUSTING SPARK PLUG:

11.3.1 If the spark plug is clogged with carbon please clean it using a plug cleaner or wire brush.

11.3.2 Always check electrode gap after cleaning.  
**Adjust gap to 0.03 inches (0.7mm to 0.8mm).**

MODEL	SPARK PLUG TYPE
GP2500R/GP2500D	F7RTC
GP3500D	F7RTC
GP4000ES	F7RTC
GP6500D	F7RTC
GP7500D	F7RTC
GP8500D	F7RTC

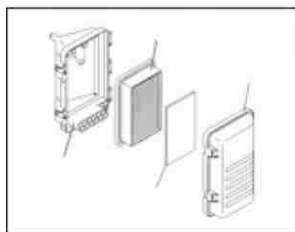
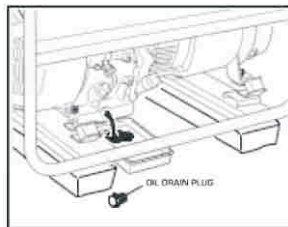
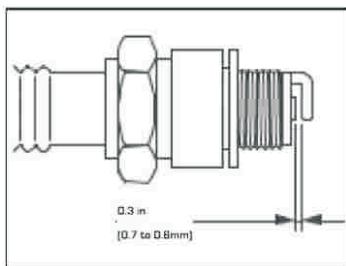

#### 11.4 **CLEANING FUEL STRAINER:**

**\*NOTE:** Dirt and water in the fuel are removed by the fuel strainer.

- 11.4.1 Remove the strainer cup and clean it properly by removing the water and dirt collected.
- 11.4.2 Clean the screen and strainer cup with gasoline.
- 11.4.3 Fasten the cup tightly to the main body and ensure that there are no fuel leaks.

#### 11.5 **FUEL HOSE REPLACEMENT:**



**Warning**

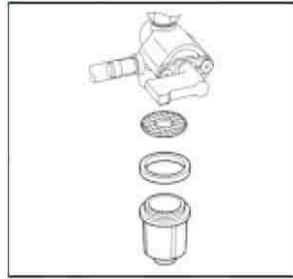

Please take extreme caution when replacing the fuel hose as gasoline is extremely flammable and dangerous. **DO NOT SMOKE OR EXPOSE TO OPEN FLAMES** whilst doing this.

- 11.5.1 Please ensure that the fuel hose is replaced every 100 hours. Do not attempt to do this whilst there fuel cock is open.
- 11.5.2 Please replace the fuel hose immediately should a leak develop or if the fuel hose is perished.

#### 11.6 **CHECKING CARBON BRUSH:**

- 11.6.1 When the brush becomes excessively worn its contact pressure with the slip ring changes and causes a rough surface on the slip ring resulting in irregular generator performance.
- 11.6.2 Check the carbon brush every 100 hours or if the generator performance is irregular.
- 11.6.3 If the brush is 0.2 inches (5mm) or less please replace it with a new one immediately.
- 11.6.4 Remove the brush cover and disconnect the wire before removing the carbon brush.
- 11.6.5 Carefully note the carbon brush direction and relative position with the slip ring when installing a new brush.

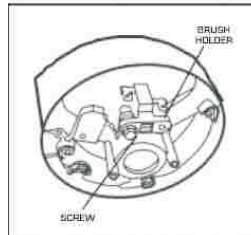
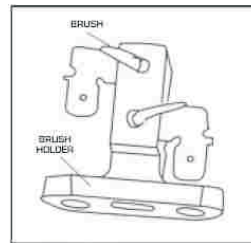



## **12. TRANSPORTING AND STORAGE:**

12.1 Before transporting the generator please ensure that the fuel cock is in the “OFF” position.



Contact with a hot engine or exhaust system can cause severe burns and or fires, always allow for the engine to cool down prior to transporting and or storing.

Always ensure that the generator is transported and or stored in a flat horizontal position. Tilting of the unit may cause fuel spillage which may result in a fire.

12.2 Before storing the generator for an extended period of time please ensure that the area of storage is free from excessive water, dust and humidity. Please follow the table below:

<u>STORAGE TIME</u>	<u>RECOMMENDED MAINTENANCE</u>
0 – 1 MONTH	<ul style="list-style-type: none"> <li>• NO PREPARATION REQUIRED</li> </ul>
1 – 2 MONTHS	<ul style="list-style-type: none"> <li>• DRAIN OUT ORIGINAL FUEL IN THE FUEL TANK AND REPLACE WITH CLEAN FUEL</li> </ul>
2 – 12 MONTHS	<ul style="list-style-type: none"> <li>• DRAIN OUT ORIGINAL FUEL IN THE FUEL TANK AND REPLACE WITH CLEAN FUEL</li> <li>• EMPTY ALL FUEL FROM THE CARBURETOR</li> <li>• EMPTY FUEL FROM THE FUEL SEDIMENT CUP</li> </ul>
>12 MONTHS	<ul style="list-style-type: none"> <li>• DRAIN OUT ORIGINAL FUEL IN THE FUEL TANK AND REPLACE WITH CLEAN FUEL</li> <li>• EMPTY ALL FUEL FROM THE CARBURETOR</li> <li>• EMPTY FUEL FROM THE FUEL SEDIMENT CUP</li> <li>• REMOVE THE SPARK PLUG AND POR A TEASPOON OF 4 STROKE ENGINE OIL INTO THE CYLINER. TURN THE ENGINE SLOWLY BY PULLING ON THE RECOIL STARTER. REINSTALL THE SPARK PLUG</li> <li>• DRAIN THE OLD OIL AND REPLACE WITH CLEAN OIL</li> <li>• AFTER REMOVAL FROM STORAGE, DRAIN THE STORED FUEL INTO A SUITABLE CONTINER AND REPLACE WITH FRSH FUEL BEFORE STARTING</li> </ul>
	<ul style="list-style-type: none"> <li>• DRAIN THE CARBURETOR BY LOOSENING THE DRAIN SCREW. DRAAIN THE FUEL INTO A SUITABLE CONTAINER. REINSTALL THE DRAIN PLUG.</li> <li>• HAVING SWITCHED THE FUEL COCK OFF, REMOVE THE SEDIMENT CUP, EMPTY THE FUEL, THEN REINSTALL THE CUP AND SECURE IT PROPERLY.</li> </ul>

**\*NOTE: NEVER STORE THE GENERATOR INSIDE A HOUSE OR OFFICE. DO NOT STORE THE GENERATOR WHERE IT IS SUSEPTABLE TO RAIN OR WATER.**

### **13. TROUBLESHOOTING:**

If the generator engine fails to start after several attempts and if there is no electricity available at the output socket then please check the chart below. If the generator still fails to start or generate electricity the please contact **GENTECH INDUSTRIES** (see the back page of this manual for the contact details).

#### **WHEN THE ENGINE FAILS TO START:**

Check if choke lever is in its proper position		Set the choke lever to the "CLOSED" position
Check if fuel cock is open.		If it is closed then open it.
Check the fuel level.		If empty then refill the fuel. Be careful not to overfill
Check if engine switch is in the "OFF" position.		Turn engine switch to the "ON" position
Check to make sure that the generator is not connected to an appliance.		If it is connected to an appliance then turn off the power switch on the appliance and unplug it.
Check the spark plug in case the spark plug cap is loose.		If it is loose then push the spark plug cap back tightly onto the spark plug.
Check spark plug for carbon build up.		Remove the spark plug and clean the electrode or replace the park plug with a new one.

#### **WHEN THERE IS NO ELECTRICITY AT THE RECEPTACLE:**

Check to make sure that the circuit breaker is in the "ON" position.		After making sure that the total wattage of the electrical appliance is within permissible limits and there are no defects in the appliances turn the circuit breaker to the "ON" position. If the circuit breakers continue to trip then please contact <b>GENTECH INDUSTRIES</b> .
Check AC and DC terminal for a possible loose connection.		Secure the connection if necessary.
Check to see if any appliance is connected whilst trying to start the generator.		Turn off the switch on the appliance and disconnect the appliance cable/plug from the receptacle. Reconnect only after the generator has started and is running smoothly.
Low and or irregular power from the generator		Check if the carbon brushes are excessively worn and replace if necessary.

# GP2500R/GP2500D/GP3500D/GP4000ES CIRCUIT DIAGRAM

## 14. WIRING DIAGRAM:

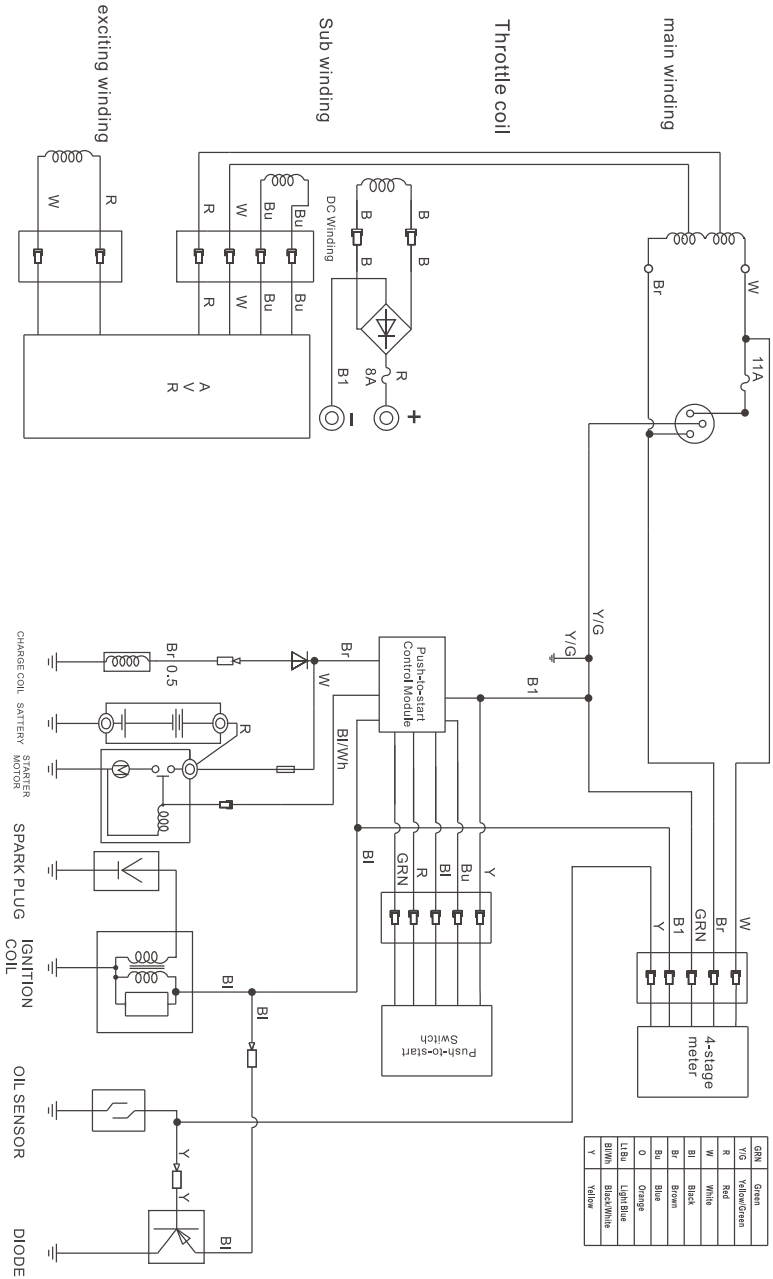

# GP6500D/GP7500D/GP8500D CIRCUIT DIAGRAM

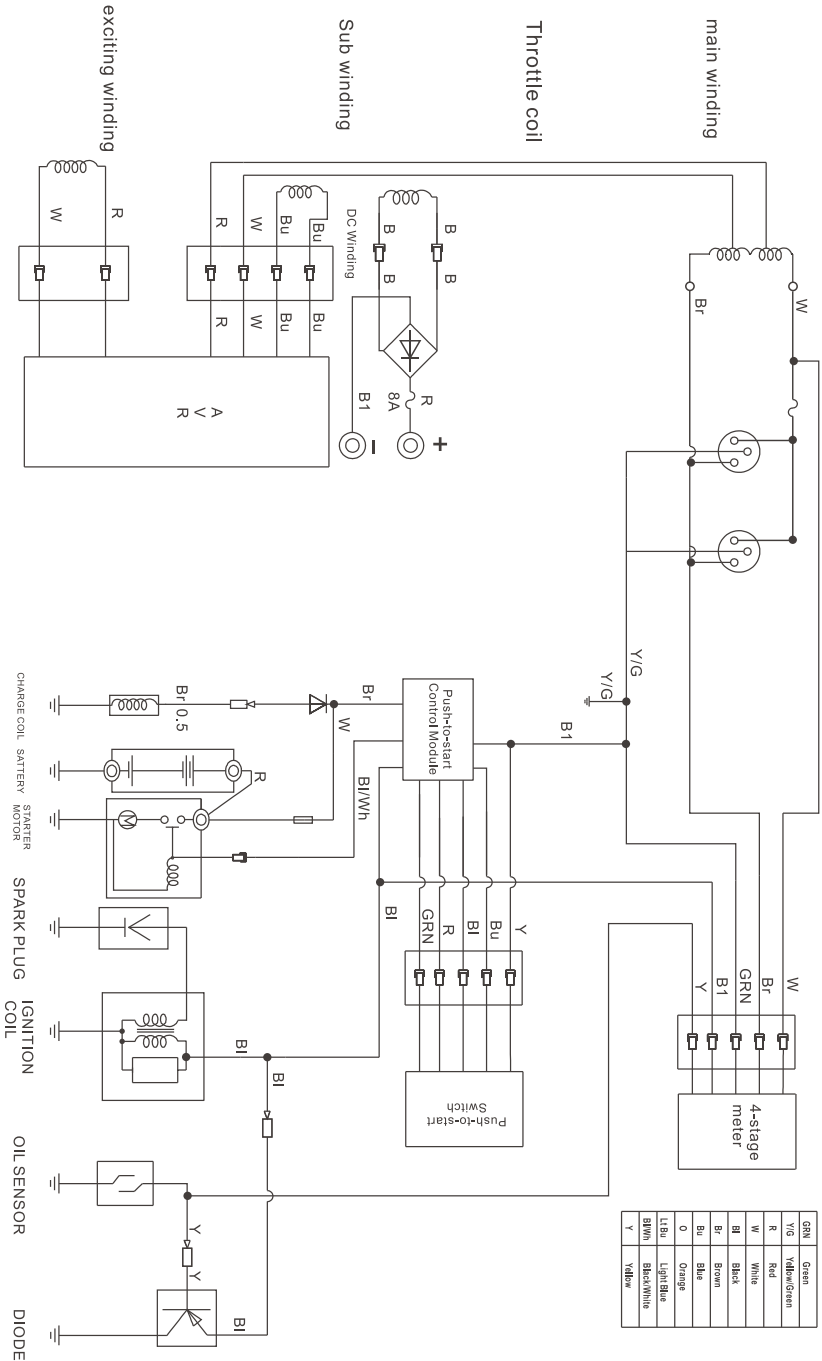



**GENTECH**  
POWER **POWER WHEN YOU NEED IT**

**FOR ALL TECHNICAL ASSISTANCE PLEASE  
CONTACT GENTECH INDUSTRIES ON**

**SOUTH AFRICA**

[customercare@gentechindustries.co.za](mailto:customercare@gentechindustries.co.za)

**NAMIBIA**

[customercare5@gentechindustries.co.za](mailto:customercare5@gentechindustries.co.za)

Telephone: +27 11 466 6790

Website: [www.gentechindustries.co.za](http://www.gentechindustries.co.za)

**Please note: This manual is designed for the GP3500D, GP4000ES, GP8500D generators.**

**FOR ALL WARRANTY INFORMATION PLEASE READ  
THROUGH YOUR LIMITED WARRANTY POLICY  
BOOKLET**